



FACTS Controllers Tuning for Stability Improvement in Power System Using Soft Computing Technique

E.Kirankumar, Prof.V.C.Veera reddy,

Research Scholar, EEE, SV University, Tirupathi, India

Rtd. Professor, EEE, SV University, Tirupathi, India

ABSTRACT: Stability exploration has drawn more attention in contemporary research for huge interconnected power system. It is a complex frame to describe the behaviour of system, hence it can create an overhead for modern computer to analyse the power system stability. The preliminary design and optimization can be achieved by low order liner model. In this paper, the design problems of SMIB-GPSS and SMIB-MBPSS are considered to compare the performance of PSO and GA optimization algorithms. The performance of both optimization techniques are then compared further. Simulation results are presented to demonstrate the effectiveness of the proposed approach to improve the power system stability.

KEYWORDS: GA, GPSS,MB-PSS, PSO, SMIB.

I. INTRODUCTION

Several modern heuristic tools were the objects of interest that have evolved dramatically in the last two decades. The tools are the key to solve optimization problems that were an impossible challenge in the past. These tools are the product of evolutionary computation, tabu search, simulated annealing, particle swarm, and so on.

With the advancement in technology, particle swarm optimization (PSO) and genetic algorithm (GA) techniques surfaced as favourable techniques to solve the optimization issues. These type of methods gained attraction to the research scholars due to their capacity to enhance complex multimodal search spaces which is connected to non-differentiable cost functions.

This paper is subjected to look at the computational performance and proficiency of the both GA and PSO optimization algorithms to plan an SMIB based model for improvement of power system stability. The outline would enhance the stability of a single-machine infinite-bus (SMIB) power system, prone in the area of disturbance. The configuration issue is developed into an optimization issue so as both GA and PSO optimization algorithms are able to search for the ideal PSS parameters.

II. SINGLE MACHINE INFINITE BUS SYSTEM (SMIB)

Algorithmic simplicity can be achieved by focusing on one machine. Therefore, the single machine infinite bus (SMIB) system came into existence instead of multi-machine power system. As shown in Figure 1, a single machine is connected to infinite bus system through a transmission line containing inductance X_g and resistance r_g .

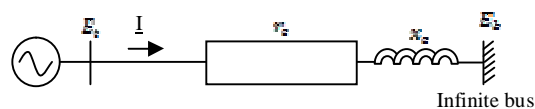

Figure 1: Single machine infinite bus system

The generator is demonstrated using transient model, as indicated by the accompanying equations.

International Journal of Advanced Research in Electrical, Electronics and Instrumentation Engineering

(An ISO 3297: 2007 Certified Organization)

Vol. 5, Issue 4, April 2016

Stator Winding Equations:

$$v_q = -r_s i_q - x'_d i_d + E'_q \quad (1)$$

$$v_d = -r_s i_d - x'_q i_q + E'_d \quad (2)$$

Where

E'_d is the d-axis transient voltage.

E'_q is the q-axis transient voltage

x'_q is the q-axis transient resistance

x'_d is the d-axis transient resistance

r_s is the stator winding resistance

Rotor Winding Equations:

$$T'_{do} \frac{dE'_q}{dt} + E'_q = E_f - (x_d - x'_d) i_d \quad (3)$$

$$T'_{qo} \frac{dE'_d}{dt} + E'_d = E_f - (x_q - x'_q) i_q \quad (4)$$

Where, T'_{do} is the d-axis open circuit transient time constant.

T'_{qo} is the q-axis open circuit transient time constant E_f is the field voltage.

Torque Equation:

$$T_{ei} = E'_q i_q + E'_d i_d + (x'_q - x'_d) i_d i_q \quad (5)$$

Rotor Equation:

$$2H \frac{d\omega}{dt} = T_{mech} - T_{ei} - T_{damp} \quad (6)$$

Then

$$T_{damp} = D \Delta\omega \quad (7)$$

Where,

T_{ei} is the electrical torque.

T_{damp} is the damping torque and

D is the damping coefficient.

T_{mech} represents mechanical torque, which is constant in this model.

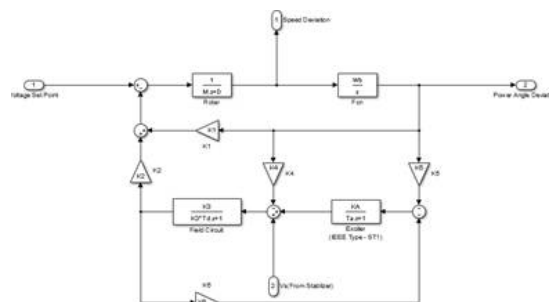

Figure 2: Heffron-Phillips model – SMIB

International Journal of Advanced Research in Electrical, Electronics and Instrumentation Engineering

(An ISO 3297: 2007 Certified Organization)

Vol. 5, Issue 4, April 2016

For the study of single machine infinite bus system a Heffron-Phillips model can be obtained by linearizing the system equations around an operating condition. The obtained Heffron model is as in figure 2 and essential mathematical equations related with SMIB framework are:

$$\frac{d}{dt} \delta = \omega_p S_m \quad (8)$$

$$\frac{d}{dt} S_m = \frac{1}{2H} [T_{mech} - T_{elec} - DS_m] \quad (9)$$

$$\frac{d}{dt} E'_q = \frac{1}{T_{d0}} [E_{fd} - E'_q + (X'_d - X'_q) i_d] \quad (10)$$

$$\frac{d}{dt} E_{fd} = \frac{1}{T_f} [K_e (V_{ref} + V_{pss} - V_t) - E_{fd}] \quad (11)$$

$$T_{elec} = E'_q i_q + (X'_d - X'_q) i_d i_q \quad (12)$$

$$S_m = \frac{\omega - \omega_t}{\omega_b} \quad (13)$$

Where,

δ = Rotor angle.

S_m = Slip speed.

T_{mech} and T_{elec} = Mechanical and Electrical torques respectively.

D = Damping coefficient.

E'_q = Transient EMF due to field flux linkage.

i_d = d-axis component of stator current.

i_q = q-axis component of stator current.

T'_{d0} = d-axis open circuit time constant.

X'_d, X''_d - d-axis reactance.

X'_q, X''_q = q-axis reactance.

E_{fd} = Field voltage.

K_e, T_f : Exciter gain and time constant.

V_t = Voltage measured at the generator terminal.

V_{ref} = Reference voltage.

Linearized equations are:

$$\Delta \delta' = \omega_p \Delta S_m \quad (14)$$

$$\Delta S'_m = \frac{1}{2H} [\Delta T_m - \Delta T_e - D \Delta S_m] \quad (15)$$

$$\Delta T_e = K_1 \Delta \delta + K_2 \Delta E'_q \quad (16)$$

$$\frac{d}{dt} \Delta E'_q = \frac{[K_3 (\Delta E_{fd} - K_4 \Delta \delta - \Delta E'_q)]}{K_3 T_{d0}} \quad (17)$$

$$\Delta V_t = K_5 \Delta \delta + K_4 \Delta E'_q \quad (18)$$

$$\frac{d}{dt} \Delta E'_{fd} = \frac{1}{T_A} [K_A (\Delta V_{ref} + \Delta V_{pss} - \Delta V_t) - \Delta E'_{fd}] \quad (19)$$

Where, Heffron-Phillip's constants are explained as:

$$K_1 = \frac{E_b E_{q0} \cos \delta_0}{X_q + X_s} + \frac{X_q - X'_d}{X_s + X'_d} E_b \sin \delta_0$$

$$K_2 = \frac{X_q + X_s}{X_s + X'_d} i_{d0}$$

International Journal of Advanced Research in Electrical, Electronics and Instrumentation Engineering

(An ISO 3297: 2007 Certified Organization)

Vol. 5, Issue 4, April 2016

$$K_3 = \frac{X_s + X'_d}{X'_d + X_s}$$

$$K_4 = \frac{X'_d - X'_q}{X_s + X'_d} E_b \sin \delta_0$$

$$K_5 = -\frac{X_q V_{d0} E_b \cos \delta_0}{(X_q + X_s) V_{T0}} - \frac{X'_d V_{q0} \sin \delta_0}{(X_s + X'_d) V_{T0}}$$

$$K_5 = \frac{X_s V_{q0}}{X_s + X'_d V_{T0}}$$

Where $E_{q0} = E'_{q0} - (X_q - X'_d) i_{d0}$

δ_0 , E'_{q0} and V_{T0} represents the values at the initial operating condition.

Figure 3 showing the SIMULINK Implementation of Phillip-Heffron model stated above.

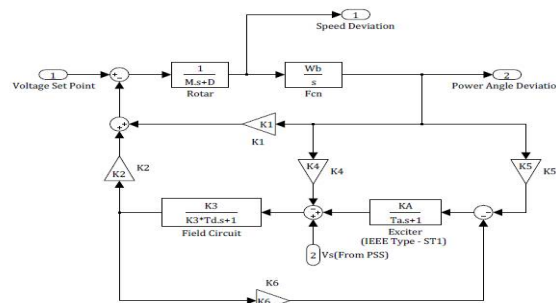

Figure 3: Simulink Implementation of SMIB



Figure 4: Simulink model for proposed SMIB

III. POWER SYSTEM STABILIZER

Network faults or operating near the limit of stability of the network cause active power oscillations as interactions between generators and network. These electromechanical oscillations of the rotor can be dampened by selectively influencing the excitation current. In these power swings distinguish between:

- Local oscillations between a generator and the other of a power plant generators. Typical oscillation frequency: 0.8 ... 2.0 Hz
- Oscillations between neighbouring power plants, typical oscillation frequency: 1.0 Hz.–2.0 Hz
- Oscillations between network areas, each consisting of several generators. Typical oscillation frequency: 0.2 Hz to 0.8 Hz.
- Global oscillations, characterized by collective in-phase oscillations of all generators within a network association. Typical oscillation frequency: below 0.2 Hz

International Journal of Advanced Research in Electrical, Electronics and Instrumentation Engineering

(An ISO 3297: 2007 Certified Organization)

Vol. 5, Issue 4, April 2016

Purpose of the PSS (Power System Stabilizer - PSS) is to capture these power oscillations and derive a signal which influences the set point of the voltage regulator.

New excitation systems for medium and high performance generators are supplied almost exclusively with an integrated power system stabilizer. For those power stations, where a complete replacement of the excitation systems is not planned, there are good reasons to upgrade the voltage regulators with PSS:

- Increasingly, network operators demand from the energy producers an active contribution to improving grid stability.
- In many cases, the operating range of the generator, especially with respect to reactive power capacity can be increased.

Power system stabilizers (PSS) are utilized on a synchronous generator to expand the damping of oscillations of the rotor/turbine shaft. The traditional PSS was initially proposed in the 1960s and traditional control hypothesis, characterized in transfer functions, was utilized for its structure. Later the progressive work of DeMello and Concordia [1] in 1969, control engineers, and additionally power system engineers, have shown incredible knowledge and made huge assistance with PSS outline and applications for both single and multi-machine power systems.

Optimal control hypothesis for stabilizing out SMIB power systems was created by Anderson [2] and also by Yu [3]. These controllers had linear property. Adaptive control methodologies have likewise been proposed for SMIB, the vast majority of which include linearization or model estimation.

Klein et al. [4, 5] demonstrated that the PSS area and the voltage characteristics of the system loads are huge component in the capacity of a PSS to expand the damping of inter-area oscillations. Currently, the traditional lead-lag power system stabilizer is broadly utilized by power system usages [6]. Additional types of PSS, for example, proportional-integral power system stabilizer (PI-PSS) and proportional-integral-derivative power system stabilizer (PID-PSS) have additionally been developed [7-8].

Certain methodologies have been connected to PSS design issue. These incorporate pole placement, H_{∞} , adaptive control, optimal control, variable structure control, and various artificial intelligence and optimization methodologies [9].

The linearized equations of GPSS are:

$$\frac{d\Delta X_w(GPSS)}{dt} = K_{GPSS} \frac{d\Delta \omega}{dt} - \frac{1}{T_w} \Delta X_w(GPSS) \quad (20)$$

$$\frac{d\Delta X(GPSS)}{dt} = \frac{T_1}{T_2} \frac{d\Delta X_w(GPSS)}{dt} + \frac{1}{T_2} \Delta X_w(GPSS) - \frac{1}{T_2} \Delta X(GPSS) \quad (21)$$

$$\frac{d\Delta V_d(GPSS)}{dt} = \frac{T_3}{T_4} \frac{d\Delta X(GPSS)}{dt} + \frac{1}{T_4} \Delta X(GPSS) - \frac{1}{T_4} \Delta V_d(GPSS) \quad (22)$$

Figure 6 and Figure 7 show the Simulink model for Generic-PSS and SMIB system connected with GPSS respectively.

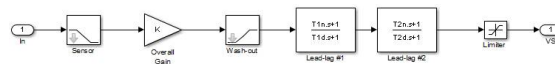

Figure 6: Simulink model for Generic-PSS

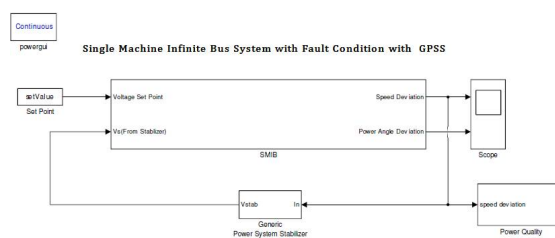

Figure 7: Simulink model for SMIB with GPSS

For most applications, a power system stabilizer, which works according to the algorithm in accordance with IEEE Standard 421.5 PSS 2A / 2B [10]. From the measured values for voltage and current generator, the electric power P_e

International Journal of Advanced Research in Electrical, Electronics and Instrumentation Engineering

(An ISO 3297: 2007 Certified Organization)

Vol. 5, Issue 4, April 2016

and the change of the rotor angular speed is calculated $\Delta\omega$. In stationary operation, deviations of the electric power used to generate the relative size and optimal stabilizing signal phase position by means of a lead / lag filter. Without special measures, a PSS also reacts to changes in the turbine power. This undesirable effect is suppressed by the rotor angular velocity is used as an additional variable (determination of the acceleration performance).

IV. MULTIBAND POWER SYSTEM STABILIZER (MB-PSS)

In the MB-PSS according to standard IEEE 421.5 PSS 4B [10] also the influences can be suppressed by changing the turbine power to the stabilizing signal. In contrast to the above-described PSS the stabilizing signal is derived both from the change of the rotor angular speed and of the electric power. Instead of a will independent Lead / Lag filter used in other three, which are each optimized for the damping of local oscillations, oscillations between network areas and global oscillations.

The primary thought of the MB-PSS is that three separate bands are utilized, individually committed to three frequency modes of oscillations; low, moderate, and high frequency. The low band is regularly connected with the power system worldwide mode, the moderate band with the inter-area modes, and the high band with the neighbourhood modes as shown in Figure 8.

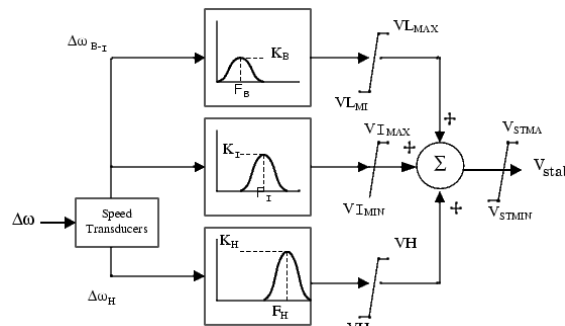

Figure 8: Multi-band power system stabilizer (MB-PSS)

Figure 9 and Figure 10 show the Simulink model for MB-PSS and SMIB system connected with MB-PSS respectively

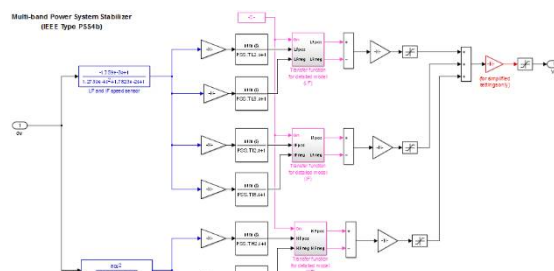

Figure 9: Simulink model for MB-PSS

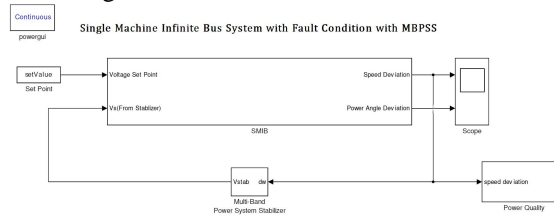

Figure 10: Simulink model for SMIB with MB-PSS

We have optimized the parameters of PSS using Genetic Algorithm and Particle Swarm Optimization.

International Journal of Advanced Research in Electrical, Electronics and Instrumentation Engineering

(An ISO 3297: 2007 Certified Organization)

Vol. 5, Issue 4, April 2016

V. GENETIC ALGORITHM

Genetic Algorithm of GA is an optimization tool that lies on the platform of Heuristic Approaches. Based on the proposal of Darwin principle of fittest survival, this method was introduced to commence optimization problems in soft computing [11]. The first category of results is termed as initial population and all the individuals are candidate solution. Simultaneous study of the population including all candidates and next phase of solutions are generated following the steps of GA [12].

An iterative application of operators on the selected initial population is the initiative process of GA. Further steps are devised based on valuation of this population. The typical routing of GA is described in following pseudo code:

1. Randomly generate initial population.
2. Employ fitness function for evaluation.
3. Chromosomes with superior fitness are valued as parents.
4. New population generation by parent's crossover with probability function.
5. Chromosome mutation with probability to defend system from early trap.
6. Repeat step 2.
7. Terminate algorithm based on satisfaction criteria.

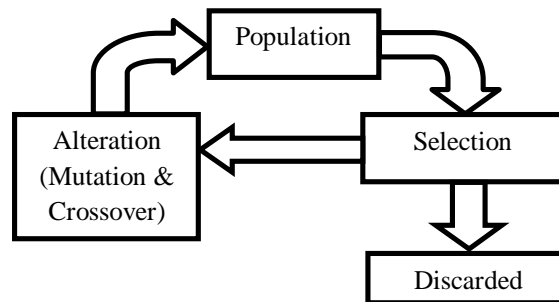

Figure 11: Genetic algorithm evolutionary cycle

VI. PARTICLE SWARM OPTIMIZATION (PSO)

PSO is a heuristic approach originally proposed by James Kennedy and Russell C. Eberhart (1995) [13]. This iterative process (Figure 12) evaluates the candidate solution of current search space. The candidate solution lies in the fitness landscape and determines minimum and maximum of objective function. As the information about objective function is not acceptable in inputs of PSO algorithm, hence the distance of solution from local and global maximum and minimum is random and not known to user. The candidate solution maintains their position and velocity and the fitness value is updated at every stage of iteration. PSO keeps a record of the best fitness value as the individual best fitness. The candidate that attains this value is referred as the individual best position and individual best solution for given problem. This best fitness value of every individual is compared and global best fitness value is generated. The candidate that attains this value is called as global best candidate solution with global best position. The individual and global best fitness are updated and even replace global and local best fitness values if necessary. The velocity and position update step is responsible for the optimization ability of the PSO algorithm. The velocity of each particle in the swarm is updated using the following equation:

$$v_i(t+1) = wv_i(t) + c_1r_1[p_i(t) - x_i(t)] + c_2r_2[g(t) - x_i(t)] \quad (23)$$

International Journal of Advanced Research in Electrical, Electronics and Instrumentation Engineering

(An ISO 3297: 2007 Certified Organization)

Vol. 5, Issue 4, April 2016

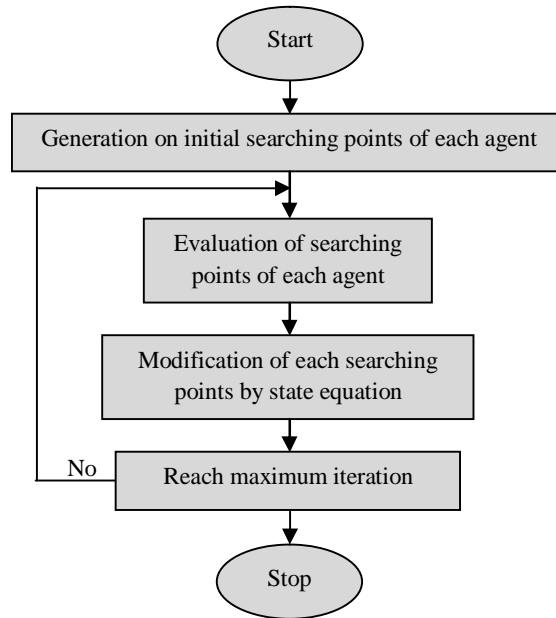

Figure 12: Flow chart of PSO algorithm

VII. SIMULATION RESULTS

The performance of proposed algorithms has been studied by means of MATLAB simulation.

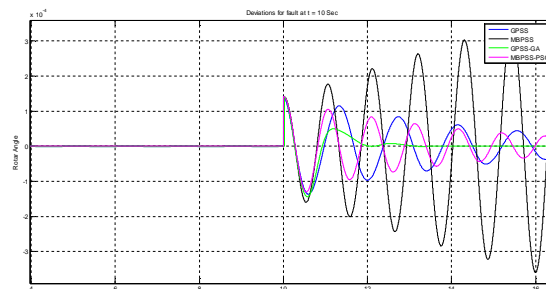

Figure 13: Comparison for rotor angle deviations of different methods for fault at t=10 sec

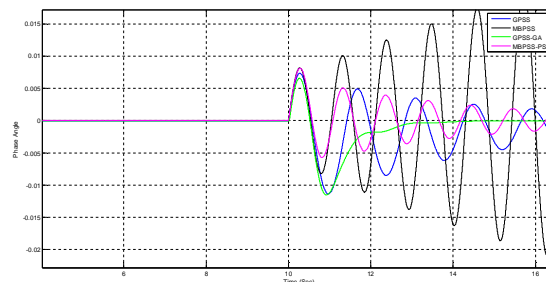

Figure 14: Comparison for phase angle deviations of different methods for fault at t=10 sec

International Journal of Advanced Research in Electrical, Electronics and Instrumentation Engineering

(An ISO 3297: 2007 Certified Organization)

Vol. 5, Issue 4, April 2016

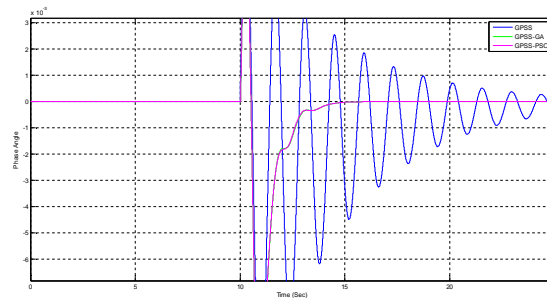

Figure 14: Comparison for phase angle deviations of GPSS, GPSS-GA and GPSS-PSO methods for fault at t=10 sec

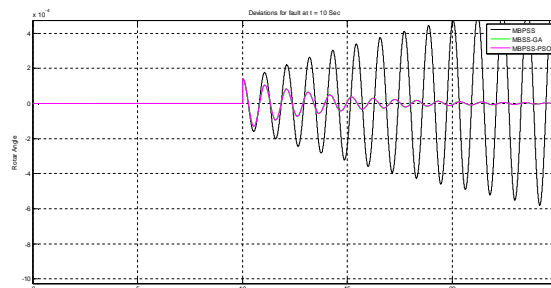

Figure 15: Comparison for rotor angle deviations of MBPSS, MBPSS-GA and MBPSS-PSO methods for fault at t=10 sec

VIII. CONCLUSION

In this paper, ensuring system stability, in order to provide faster responses over a wide range of power system operation, SMIB-GPSS and SMIB-MBPSS were developed and its parameters were tuned by robust evolutionary algorithms which offer flexibility to designers for achieve a compromise between conflicting design objectives, the power angle and speed deviation in SMIB.

The design problem of robustly tuning GPSS and MBPSS parameters are formulated as an optimization problem according to the time domain based objective function which is solved by the Particle Swarm Optimization and Genetic Algorithm techniques. The effectiveness of the proposed PSO and GA based PSS is demonstrated on a SMIB power system. It was found that the PSO based system outperforms than the GA based technique. The design was done off-line, which also can be performed on-line for a time varying or time dependent systems so that the computational time and global optimization on a single-run process is of prime importance. Application of the developed method to a typical problem, especially in comparison with such traditional implementations illustrated the performance and effectiveness in achieving the stated design objectives

REFERENCES

- [1] F. P. Demello and C. Concordia, "Concepts of Synchronous Machine Stability as Affected by Excitation Control," IEEE Trans.on Power Apparatus and Systems, vol. PAS-88, no. 4, April 1969.
- [2] Angeline J. H, "The control of a synchronous machine using optimal control theory," Proceedings of the IEEE, vol. 1, pp. 25–35, 1971.
- [3] Yu YN and Moussa HAM, "Optimal stabilization of a multi-machine system," IEEE Transactions on Power Apparatus and Systems, vol. 91,no. 3, pp. 1174–1182,1972.
- [4] Klein, M.; Rogers, G.J.; Kundur, P., "A fundamental study of inter-area oscillations in power systems," IEEE Transactions on Power Systems, Volume: 6 Issue: 3, Aug. 1991, Page(s): 914 -921.
- [5] Klein, M., Rogers G.J., Moorty S., and Kundur, P., "Analytical investigation of factors influencing power system stabilizers performance", IEEE Transactions on Energy Conversion, Volume: 7 Issue: 3, Sept. 1992, Page(s): 382 -390.
- [6] G. T. Tse and S. K. Tso, "Refinement of Conventional PSS Design in Multimachine System by Modal Analysis," IEEE Trans. PWRs, Vol. 8, No. 2, 1993, pp. 598-605.
- [7] Y.Y. Hsu and C.Y. Hsu, "Design of a Proportional-Integral Power System Stabilizer," IEEE Trans. PWRs, Vol. 1, No. 2, pp. 46-53, 1986.
- [8] Y.Y. Hsu and K.L. Liou, "Design of Self-Tuning PID Power System Stabilizers for Synchronous Generators," IEEE Trans. on Energy Conversion, Vol. 2, No. 3, pp. 343-348, 1987.



ISSN (Print) : 2320 – 3765
ISSN (Online): 2278 – 8875

International Journal of Advanced Research in Electrical, Electronics and Instrumentation Engineering

(An ISO 3297: 2007 Certified Organization)

Vol. 5, Issue 4, April 2016

- [9] V. Samarasinghe and N. Pahalawaththa, "Damping of Multimodal Oscillations in Power Systems Using Variable Structure Control Techniques", IEEE Proc. Genet. Transm. Distrib. Vol. 144, No. 3, Jan. 1997, pp. 323-331.
- [10] Kamwa I, Grondin R, Trudel G., "IEEE PSS2B versus PSS4B: the limits of performance of modern power system stabilizers", IEEE Transactions on Power Systems, Vol. 20, Issue 2, pp. 903-915, May 2005.
- [11] J.H. Holland, "Adaptation in Natural and Artificial Systems", University of Michigan Press, 1975.
- [12] D.E. Goldberg, "Genetic Algorithms in Search, Optimization, and Machine Learning", Addison-Wesley, 1989.
- [13] James Kennedy and Russell Eberhart, "Particle Swarm Optimization", In Proceedings of the IEEE International Conference on Neural Networks, Vol. 4, pp. 1942-1948, 1995.

BIOGRAPHY

Mr.E.Kiran Kumar presently doing Ph.D in SV University college of engineering, Tirupathi. He studied B.tech in SVCET Chittoor and M.Tech in Sree Vidyanikethan Engineering college, Tirupathi. He is having more than 5 years of teaching experience. Areas of interests in power systems, Control systems and FACTS.

Prof. V. C. Veera Reddy presently working as a professor in EEE department of S.V.U. College of Engineering, Tirupathi. He awarded Ph.D for his work "Modeling & Control of Load frequency using New Optimal Control strategy" from S.V.U. in the year 1999. Have 28 years of experience in teaching and worked in various levels. Guided a number of research scholars. Attended a number of national & international conferences. Areas of interest include Distribution systems, Genetic Algorithms, Fuzzy Systems, ANN.